

# Isuzu Commercial Marine

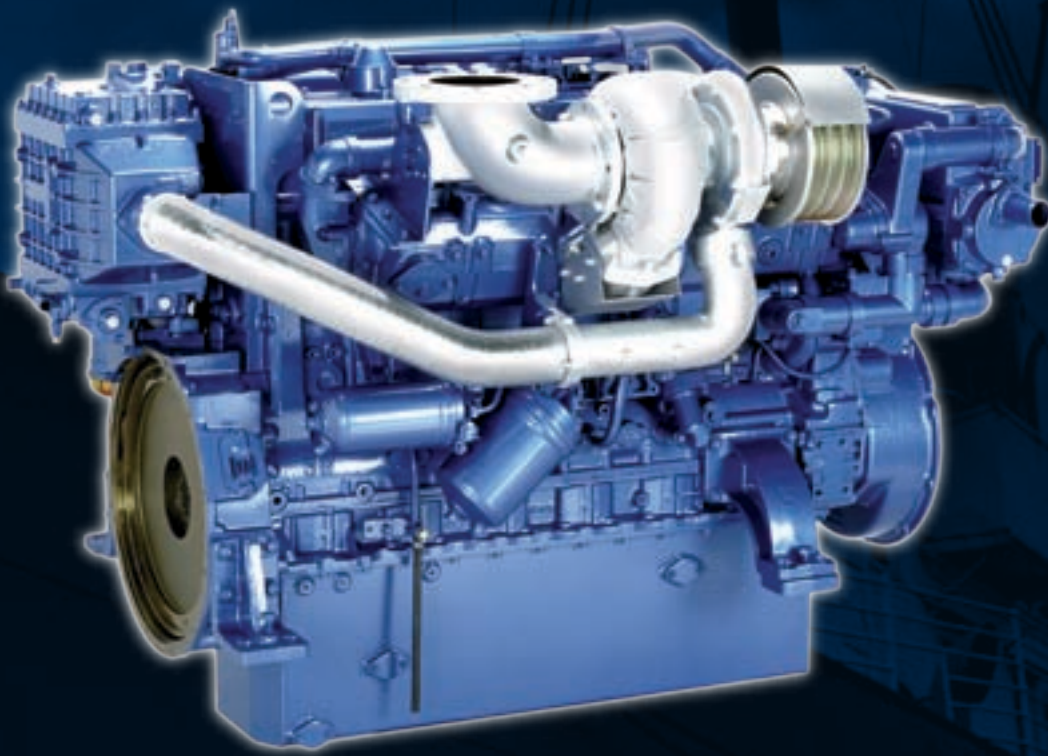

## 6WG1AB1

M1 Rating 505 HP @ 1800 RPM

Conforms to U.S. EPA Tier 2 emission regulations

### Features:

- 15.7 liter displacement
- Bore and Stroke: 5.79 x 6.06
- Torque: 1681 lbs./ft.
- Choice of heat exchanger cooled or keel cooled
- SAE housing for easy transmission mounting
- Mechanical fuel system with proven reliability
- Oversized air cleaner
- Oil filters
- Water/fuel separator
- 24 Volt electrical system
- Oil sump pump
- Deep sump oil pan
- Dry fit cylinder liners
- Glow plugs for cold start
- Zinc anode protection
- Several fluid service drains
- Complete instrument panel

Isuzu power. Make waves.

**ISUZU**

**DIESEL**

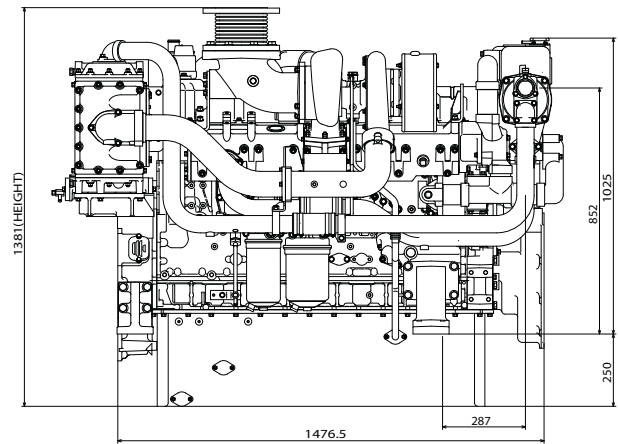
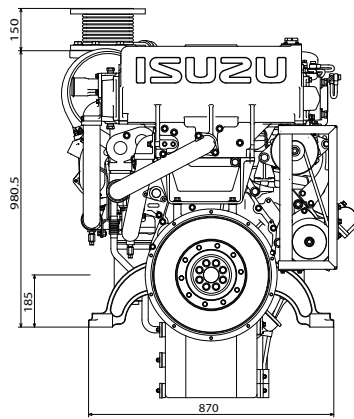
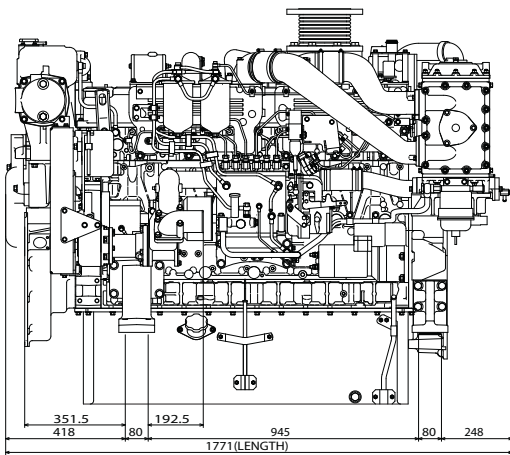

Weight Bobtail: Heat Exchanger 1470 kg (3240 lbs.) Keel Cool 1460 kg (3219 lbs.)

### 6WG1AB1 Performance Curves

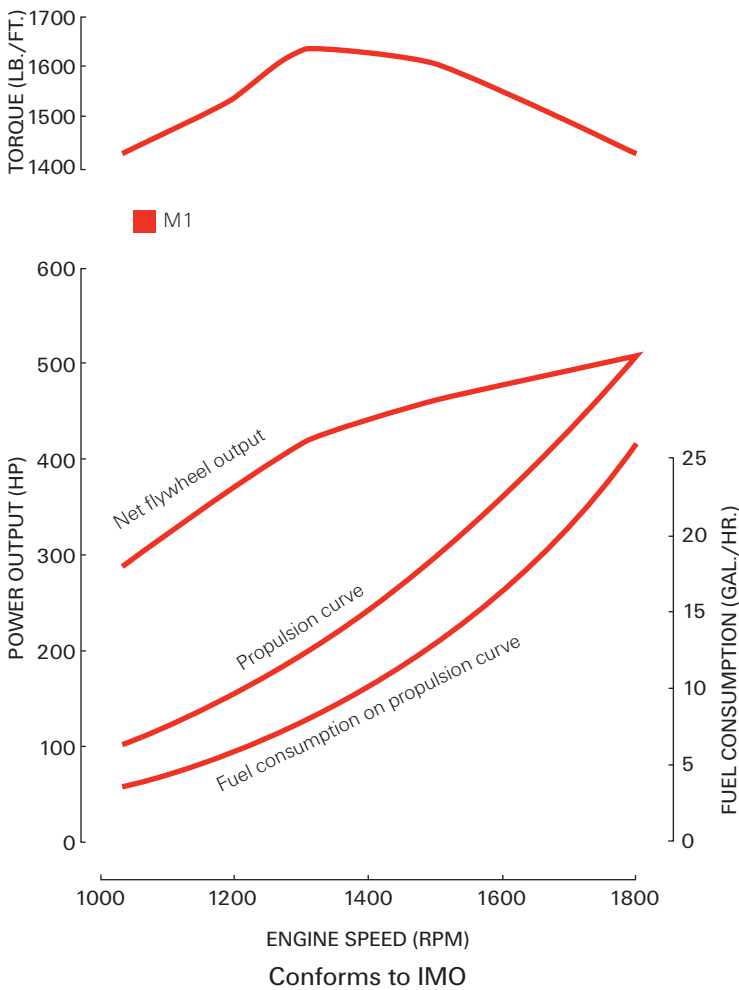

### Standard Equipment:

- 24V, 7.4 kW starter
- 24V, 50 amp alternator
- SAE housing and flywheel
- Left hand rotation (looking at flywheel)
- Seawater pump
- Dry exhaust elbow
- Oil sump pump
- Owner's manual

### Available Options:

- Heat exchanger or keel cooling
- Nikko marine transmissions
- Vibration isolators
- Extended wire harness
- Dual station panel
- Keel coolers
- Front PTO (capacity 400 HP)
- Bilge pump
- Service and parts manuals

### Marine Rating (M1)

Marine propulsion engines that operate at full power up to 24 hours per day. These engines usually operate over 4,000 hours per year and include bottom trawlers, tugboats, dredges and ferry boats.

### Isuzu Corporate Headquarters

46401 Commerce Center Drive  
Plymouth, Michigan 48170  
Phone: 734.582.9470  
Fax: 734.455.7581

Lunenburg Foundry & Engineering Limited PO BO